

CCTV Camera

WV-140 & 144

# Operating Instructions

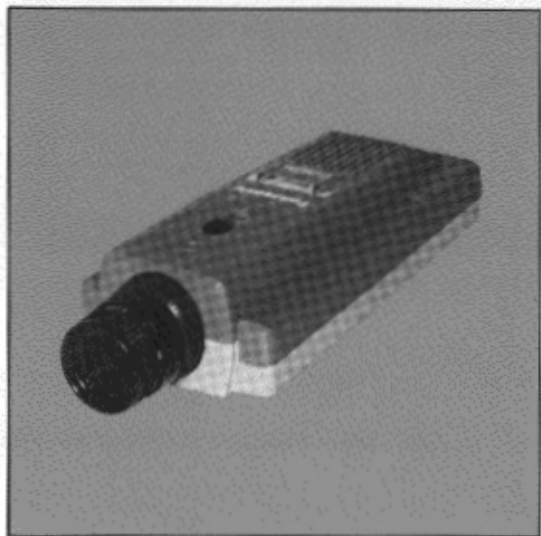

**Panasonic**<sup>®</sup>

Before attempting to connect or operate this product, please read these instructions completely.

**CAUTION****RISK OF ELECTRIC SHOCK  
DO NOT OPEN**

**CAUTION:** TO REDUCE THE RISK OF ELECTRIC SHOCK, DO NOT REMOVE COVER (OR BACK). NO USER-SERVICEABLE PARTS INSIDE. REFER SERVICING TO QUALIFIED SERVICE PERSONNEL.



SA 1965

The lightning flash with arrowhead symbol, within an equilateral triangle, is intended to alert the user to the presence of uninsulated "dangerous voltage" within the product's enclosure that may be of sufficient magnitude to constitute a risk of electric shock to persons.



SA 1966

The exclamation point within an equilateral triangle is intended to alert the user to the presence of important operating and maintenance (servicing) instructions in the literature accompanying the appliance.

The serial number of this product may be found on the top cover of the unit.

You should note the serial number of this unit in the space provided and retain this book as a permanent record of your purchase to aid identification in the event of theft.

Model No. \_\_\_\_\_

Serial No. \_\_\_\_\_

**WARNING:** TO PREVENT FIRE OR SHOCK HAZARD, DO NOT EXPOSE THIS APPLIANCE TO RAIN OR MOISTURE.

# CONTENTS

	Page
PREFACE .....	1
FEATURES .....	1
PRECAUTIONS .....	2
MAJOR OPERATING COMPONENTS .....	3
CONTROLS AND THEIR FUNCTIONS .....	4
INSTALLATION OF CAMERA .....	5
LENSES .....	6
SELECTION OF LENS .....	6
ILLUMINATION .....	7
CONNECTIONS .....	7
POWER CABLE .....	7
VIDEO CABLE .....	8
ADJUSTMENTS .....	9
SPECIFICATIONS .....	11
OPTIONAL ACCESSORIES .....	12

## PREFACE

Security equipment must be on guard day-in and day-out. Reliability is a must. Panasonic's CCTV cameras are a product of our vast experience in CCTV design.

They are attractively designed and stand out from their surroundings.

The WV-140 and WV-144 cameras are designed and built for easy installation and top/bottom mounting, making them a logical choice for dependable closed circuit television.

## FEATURES

- A Choice of Models for either 120V AC 60Hz (WV-140) or 24V AC 60Hz (WV-144) power source.
- Compact and lightweight; easy to carry and install.
- Highly sensitive separate mesh 1/2" pick-up tube (Vidicon: Type S4152)
- Internal or line locked synchronizing system.
- Will operate with incandescent illumination as low as 1 footcandle (10 lux) with f1.4 lens used.
- Automatic light compensation allows use under a wide range of lighting conditions.
- Pick-up tube Mechanical Focus position is externally adjustable.
- Top or bottom mounting for flexibility in mounting position.
- Interchangeable with C-mount lens.
- High reliability is assured by using high-grade components.
- White clip circuit produces a better picture when extremely bright objects come into view.

## PRECAUTIONS

### 1. Do not attempt to disassemble the camera.

To prevent electric shock, do not remove screws or cover. There are no user-serviceable parts inside. Refer servicing to qualified service personnel.

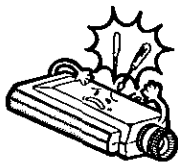

### 2. Handle this camera with care

Avoid jarring or striking the camera as it contains a sensitive pick-up tube which can be damaged by improper handling. Always keep the camera in a horizontal position when transporting.



### 3. Lens and pick-up tube protection

When the camera is not in use, turn Camera OFF and insert the body cap into lens mount hole when the lens is not installed.

Avoid turning the power ON with the lens capped as this will shorten the life of the pick-up tube.

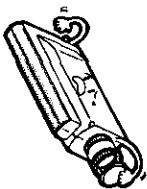

### 4. Never face the camera toward the sun.

Whether the camera is in use or not, never face it toward the sun or an extremely bright object, as this will permanently damage the pick-up tube.

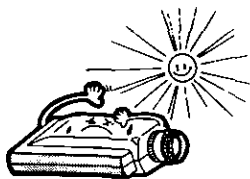

### 5. Do not use the camera beyond its temperature, humidity or power source ratings.

- Designed for indoor use. Ambient temperature range must not beyond  $14^{\circ}\text{F} \sim 122^{\circ}\text{F}$  ( $-10^{\circ}\text{C} \sim +50^{\circ}\text{C}$ ).
- Avoid using the camera when humidity is above 90%.
- The input power source must be 120V AC 60Hz for WV-140, 24V  $\begin{matrix} +15\% \\ -12\% \end{matrix}$  (21  $\sim$  28V) AC 60Hz for WV-144.

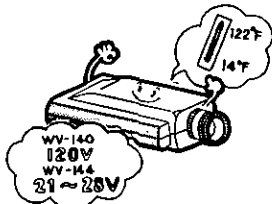

# MAJOR OPERATING COMPONENTS

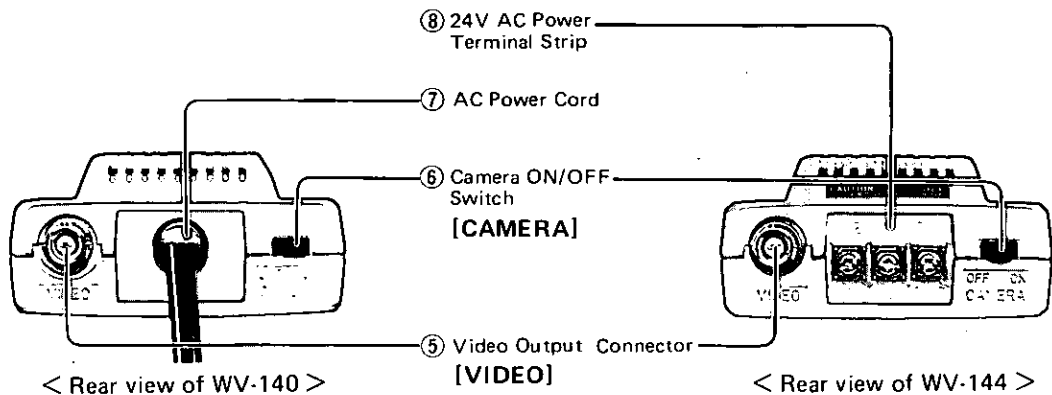
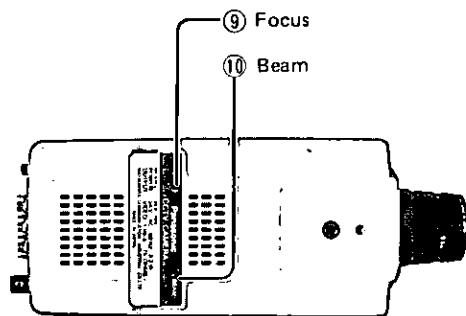
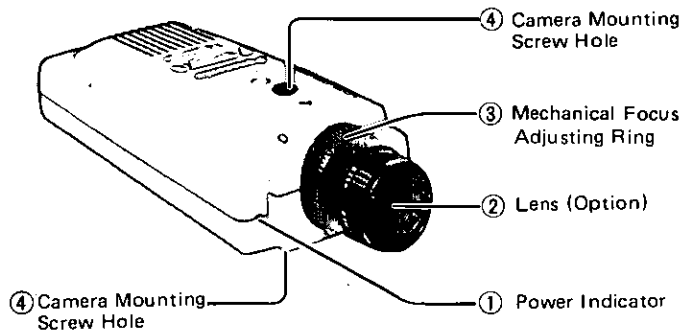

## CONTROLS AND THEIR FUNCTIONS

### ① Power Indicator

### ② Lens (Option)

### ③ Mechanical Focus Adjusting Ring

Adjust the distance from the pick-up tube to the lens by moving the pick-up tube carrier along its optical axis. If required, this allows the minimum working distance between the camera and subject to be reduced. In the case of a zoom lens, focus tracking can be adjusted with this control.

See page 9.

### ④ Camera Mounting Screw Holes

Standard photographic pan-head screw size ( $\frac{1}{4}$ "–20). See page 5.

### ⑤ Video Output Connector [VIDEO]

Use a coaxial cable with a BNC connector. Video output signal is fed to a video monitor or VTR.

### ⑥ Camera ON/OFF Switch [CAMERA ON/OFF]

### ⑦ AC Power Cord – Model WV-140

2-wire power cord for connecting to power outlet (120V AC, 60Hz).

⑧ **24V AC Power Terminal Strip – Model WV-144**  
Accepts 24V AC 60Hz power source. Be sure to connect grounding lead to the GND terminal. See page 8.

### ⑨ Electrical Focus Control [FOCUS] ⑩ Beam Control [BEAM]

These controls have been preset at the factory for optimum picture quality. The user should not change these control settings as this may result in severe degradation of camera performance or permanent damage to the pick-up tube.

Readjustment of these controls should be made only by qualified service personnel. See page 9 and 10.

## INSTALLATION OF CAMERA

### Mounting at top

- This camera is originally designed to be mounted by two  $\frac{1}{4}$ " - 20 hole ④ on its top. This hole is the standard photographic pan-head screw size.

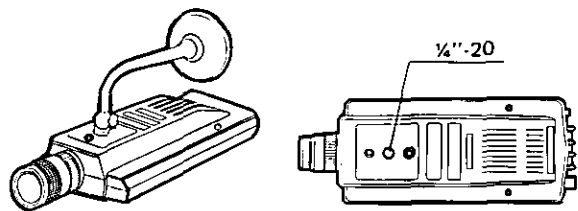
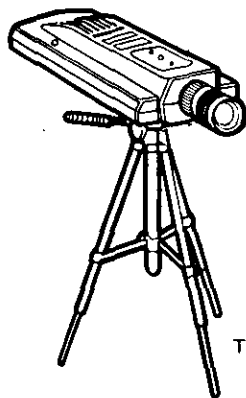

Fig. 2

### Mounting at bottom

- If the camera must be mounted at the bottom's on a tripod, use one  $\frac{1}{4}$ " - 20 hole on its bottom.



Tripod

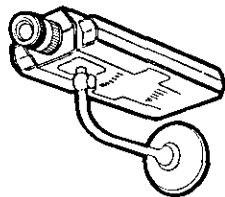

Wall Mounting Bracket

Fig. 3

It is recommended to mount the camera at the top for stability when the camera with zoom lens whose weight is more than 1.0kg is mounted on the mounting bracket WV-7010/7015.



# LENSES

## Selection of Lens

### (A) Lens Mounting

"C" mount lens may be used.

### (B) Focal length of lens vs. viewing dimensions.

If object size and the distance between the object and the television camera are known, a lens of the proper focal length must be selected.

The proper focal length can be determined by the following equations or from the chart shown in Fig. 4.

If a specific width must be viewed:  $f = 6.2 L/W$

If a specific height must be viewed:  $f = 4.65 L/H$

f : Focal length of lens (mm)

W: Object width (ft.)

H: Object height (ft.)

L: Distance between object and television camera. (ft)

The height or width of an object, placed at a particular distance that can be picked up with a specific lens, can be calculated from the following equations or from the chart shown in Fig. 4.

In case object width is important:

$$\text{(Approx.) } W = \frac{6.2L}{f}$$

In case object height is important:

$$\text{(Approx.) } H = \frac{4.65L}{f}$$

Note: Effective coverage angle will be 5 to 10% less of the following angle because video monitor is generally overscanned 5 to 10%.

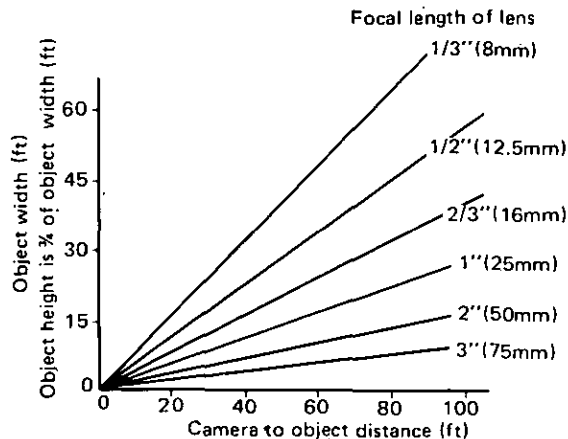

Fig. 4

## ILLUMINATION

### About Illumination

Generally, the greater object illumination, the higher quality will be the resulting picture. Ambient conditions, object reflection factor, pick-up tube spectral sensitivity loss, and loss of incoming light due to lens aperture ratio must all be considered. However, the following illumination requirements must be met.

- Minimum illumination required for rated equipment performance:  
1 footcandle (10 lux)  
(Incandescent lamp; f1.4 lens used)
- Recommended illumination:  
10 footcandles (100 lux)

## CONNECTIONS

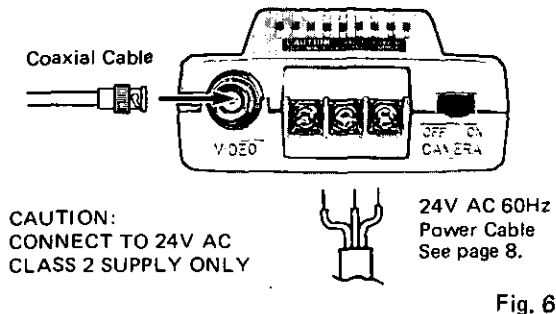
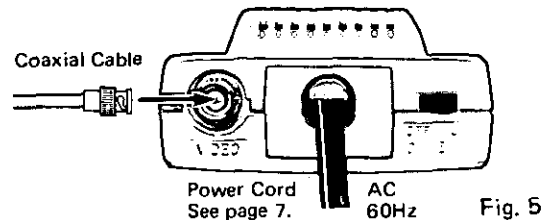

### Power Cable

#### A. WV-140

1. Keep the camera POWER switched OFF during installation.
2. Connect the AC Power Cord ⑦ to a 60Hz electrical outlet 120V AC.

## B. WV-144

1. Keep the camera POWER switched OFF during the installation.
2. A power supply of 24V AC 60 Hz is required.
3. Connect the power cable to the 24V AC Power Terminal Strip ⑧ on the rear panel of the camera.

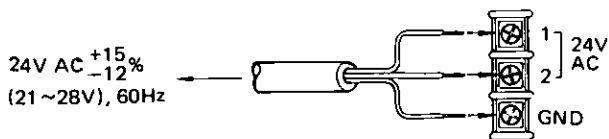

Be careful not to obstruct the operation of CAMERA ON/OFF Switch ⑥.

Fig. 7

Recommended wire guage sizes for 24V AC line.

Copper wire size (AWG)	# 24 (0.22mm <sup>2</sup> )	# 22 (0.33mm <sup>2</sup> )	# 20 (0.52mm <sup>2</sup> )	# 18 (0.83mm <sup>2</sup> )
Length of Cable (Approx.) [ft]	420	600	950	1550

Wire should have a flame-retardant rating (FR-1).

## ADJUSTMENTS

### 1. Mechanical Focus Adjusting Ring ③.

The camera will focus from about 10 inches (25cm) to infinity with the f1.4 12mm lens and with the pick-up tube in its factory set position.

For a fixed focal lens, non-standard lenses can be used easily by changing the pick-up tube position with a mechanical focus adjusting ring. See Fig. 9. For a zoom lens, focus tracking can be adjusted with this ring.

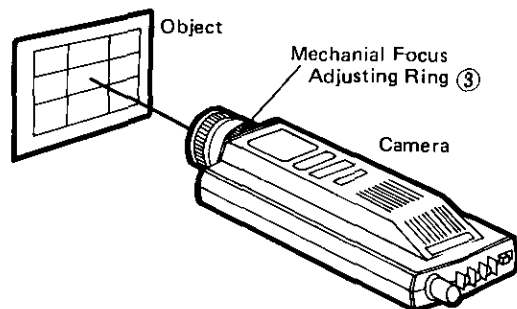

Fig. 9

- (1) Set zoom lens at Tele position
- (2) Adjust the focus ring on the lens for best focus.
- (3) Set zoom lens at Wide position.
- (4) Adjust the mechanical focus adjusting ring for best focus.
- (5) Zoom in again and adjust the focus ring on the lens for best focus.
- (6) Zoom out again and adjust the mechanical focus adjusting ring for best focus.
- (7) Repeat the process (1) – (6) until the focus tracks over the zoom range of the lens.

**The following internal camera adjustments should be made by qualified video service technicians or system installers.**

### 2. Target Control

Turn the Target Control on the PCB slowly counterclockwise until the picture just disappears. Then slowly turn it back until the picture appears with the optimum contrast. This control has been preset at the factory for optimum picture quality.

### 3. Beam Control

Turn the Beam Control on the PCB fully counterclockwise. Then turn it clockwise until the high-

lights in the picture are just resolved, or discharged and advance the control slightly in the same direction. This control has been preset at the factory for optimum picture quality.

**4. Electrical Focus Control**

Turn the Focus Control on the PCB slowly until picture on monitor is sharpest. This control has been preset at the factory for optimum picture quality.

**5. Internal Sync Selector Switch [LL-INT]**

This switch selects the internal sync mode.

LL: Internal vertical line locked sync mode

INT: Internal sync mode

This switch has been preset at the factory to the LL position.

## SPECIFICATIONS

Power Source:	120V AC 60Hz (WV-140), 24V AC 60Hz (WV-144)
Power Consumption:	Approx. 3.1W (WV-140), Approx. 3.2W (WV-144)
Scanning:	525 lines/60 fields/30 frames
Synchronizing:	Internal or vertical line locked (switchable internally)
Video Output:	1.0 Vp-p composite/75 ohms (BNC connector)
Horizontal Resolution at Center:	500 lines
Signal to Noise:	43 dB (typical)
Automatic Light Compensation:	10,000 : 1
External Controls:	Mechanical Focus, CAMERA ON/OFF
Pick-up Tube:	1/2" separate mesh vidicon Type S4152
Required Minimum Illumination:	More than 1 footcandle (10 lux) with f1.4 lens used under incandescent light
Ambient Operating Temperature:	14°F ~ 122°F (-10°C ~ +50°C)
Ambient Operating Humidity:	Less than 90%
Lens Mounting:	Standard C Mount
Maximum Allowable Lens Weight:	0.9 lbs (0.4 kg)
Camera Mounting:	Top: One ¼" – 20 threaded hole Bottom: One ¼" – 20 threaded hole
Dimensions (Approx.):	WV-140: 3-9/16" (W) x 1-7/8" (H) x 7-5/8" (D) [90(W) x 47.5(H) x 194(D) mm] WV-144: 3-9/16" (W) x 1-7/8" (H) x 7-13/16" (D) [90(W) x 47.5(H) x 198(D)]
Weight (Approx.):	WV-140: 1.2 lbs (0.55 kg) WV-144: 1.0 lbs (0.45 kg)

Specifications are subject to change without notice.

## OPTIONAL ACCESSORIES

- Fixed Focal length lens  
WV-LM12/2 (f1.4 12mm)
- Wide Angle lens Adaptor  
WV-CL51 (0.5X)

**PANASONIC INDUSTRIAL COMPANY, Division of Matsushita Electric Corporation of America**

Executive Office: One Panasonic Way, Secaucus, New Jersey 07094 (201) 348-7000

Audio-Video Systems Division Executive Office: One Panasonic Way, Secaucus, New Jersey 07094 (201) 348-7000

Northeast Regional Office: Panasonic Audio-Video Systems, 333 Meadowlands Parkway, Secaucus, New Jersey 07094 (201) 348-7620

Northwest Regional Office: Panasonic Audio-Video Systems, 4060 Lind Avenue, Renton, Washington 98055 (206) 251-5209

Midwest Regional Office: Panasonic Audio-Video Systems, 425 East Algonquin Road, Arlington Heights, Illinois 60005 (312) 981-4826

Southeast Regional Office: Panasonic Audio-Video Systems, 3 Meca Way, Norcross, Georgia 30093 (404) 923-3663

Southwest Regional Office: Panasonic Audio-Video Systems, 1825 Walnut Hill Lane Irving, Texas 75062 (214) 258-2828

Western Regional Office: Panasonic Audio-Video Systems, 6550 Katella Avenue, Cypress, California 90630 (714) 895-7200

**PANASONIC HAWAII INC.**

91-238 Kauhū Street Ewa Beach P.O. Box 774 Honolulu, Hawaii 96808-0774 (808) 682-2851

**MATSUSHITA ELECTRIC OF CANADA LIMITED**

5770 Ambler Drive, Mississauga, Ontario, Canada L4W 2T3 (416) 624-5010

**PANASONIC SALES COMPANY**

Ave 65 de Infanteria, Km. 9.7, Victoria Industrial Park, Carolina, Puerto Rico 00630 (809) 769-4320